



**K&K Systems, inc.**

Traffic Safety Products Manufacturer

# ARROW BOARDS

TRAILER AND VEHICLE MOUNT

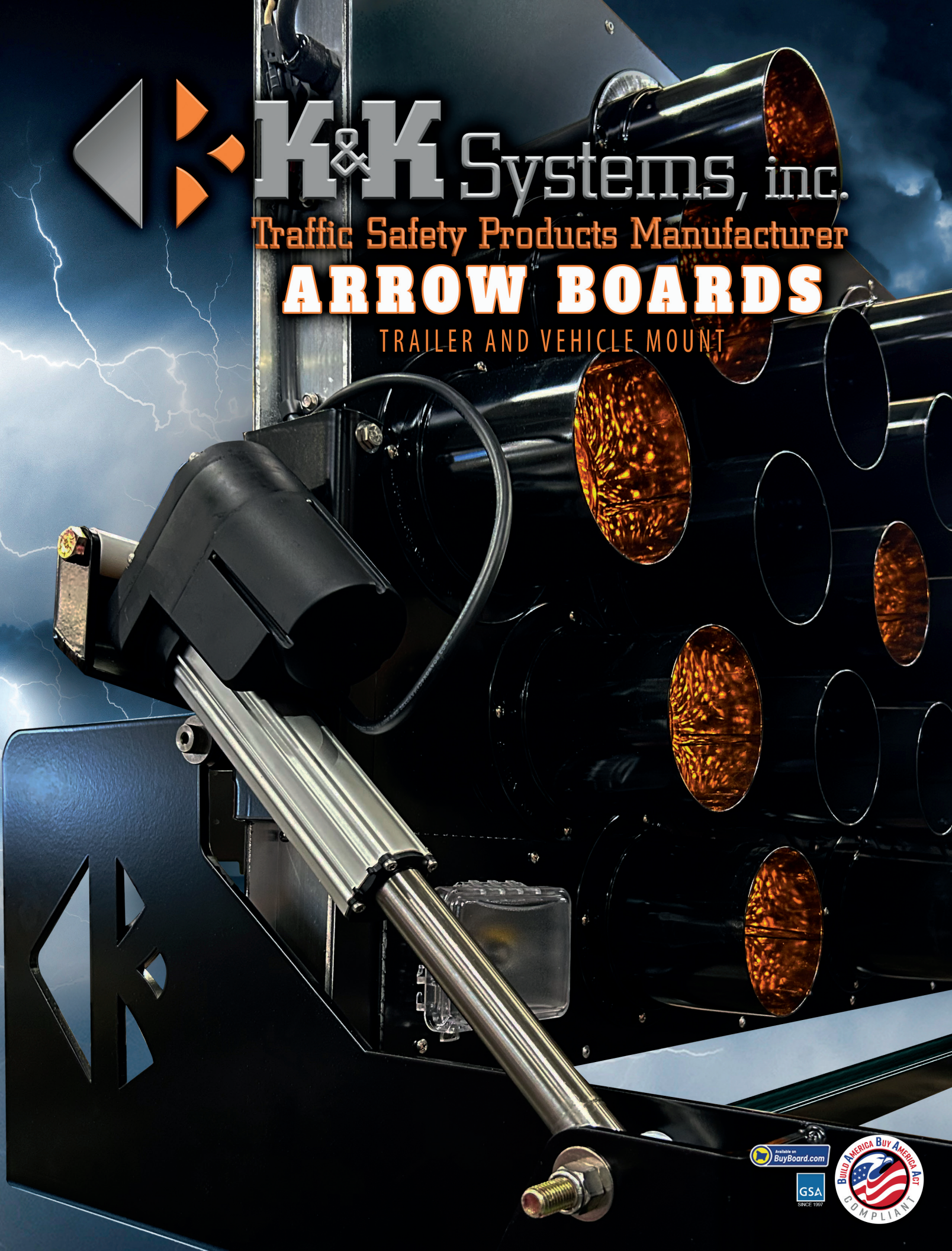

# TRAILER MOUNTED MODELS

K&K Systems strives to meet your needs with trailer-mounted and vehicle-mounted Arrow Boards in a variety of sizes with 15 and 25 LED lamp configurations. Arrow Boards are effective in providing advanced warning and directional information to keep motorists informed, traffic flowing, and to provide safer working zones.

K&K Systems Fold & Go and 360° Arrow Boards utilize energy efficient LED and solar power technology for continuous operation. Our standard systems have two 18 amp maintenance-free batteries concealed within the display to deter theft.

K&K Arrow Boards trailer mounts are available in 15 or 25 lamp configuration. The built in smart charge controller and the optional remote controller allow for 8 modes for 15 lamp units or 13 modes for 25 lamp units.

K&K trailers are powder coated safety orange and features four corner jacks and a tongue jack for stability.

Our displays are fabricated from aluminum composite, and are raised and lowered with a hand operated winch.

## FEATURES

- ▶ Easy to Operate & Maintain
- ▶ Super Bright LED Technology
- ▶ MUTCD Compliant
- ▶ 8 and 13 Modes depending on number of lamps
- ▶ Auto Dimming
- ▶ Durable Powder Coat Finish Resists the Elements
- ▶ DOT Approved
- ▶ 4 Corner Jacks + Tongue Jack
- ▶ 15" Tires
- ▶ Solar-Powered
- ▶ Concealed Maintenance-Free Batteries
- ▶ Removable Tongue
- ▶ Sleek Design



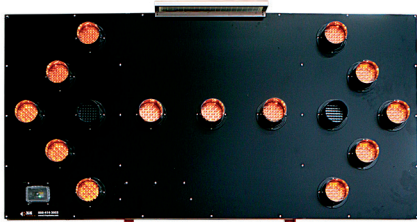

Fold & Go 15

## FOLD&GO 15 AND 25 LAMP

The Fold & Go is designed so that the display folds down for less wind resistance in transit. The solar panel on the back of the display allows the batteries to charge while folded. Simply crank the winch to raise the board into the upright/ deployed position.

### FOLD&GO TRAILER SPECS

Width: 96"  
Length without Tongue: 76"  
Length with Tongue: 115"  
Transport Height: 82"  
Weight: 605 lbs.

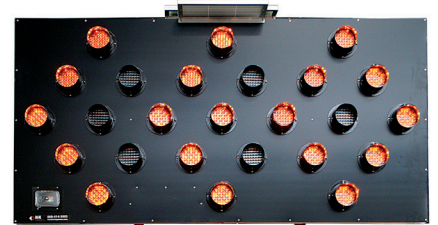

Fold & Go 25



Transit Configuration



### CONCEALED BATTERY COMPARTMENT

Our sleek design is attributed to the easily accessible battery compartment located inside the display. It neatly houses the batteries to create a clean, smooth look while deterring theft. A second solar panel mounted on the back of the panel allows the batteries to charge while the Fold & Go Arrow Board is in the transportation configuration.

### AVAILABLE ON REQUEST

#### 360° ROTATING TELESCOPIC

The Telescopic 360° Rotating Arrow Board extends to a full height of 7 feet to the bottom of the board with a transport height of 87". It can rotate a full 360° left and right.



Call 888.414.3003 or visit [k-systems.com](http://k-systems.com) for more information.

### GENERAL TRAILER SPECS

**Salt Spray:** 1,000 hours  
**Finish:** Powder Coat  
**Main Frame:** 2" x 2" x 1/8" tubular steel  
**Wheels:** 15"  
**Axle:** 2,000 lbs. double leaf spring  
**Fenders:** 16 gauge  
**Jacks:** (4) adjustable corner jacks plus (1) one adjustable tongue jack  
**Hitch:** 2" ball, 1/4" safety chains with hooks  
**Arrow Panel Lift:** Gear ratio: 4:1,  
**Load Capacity:** 1200 lbs.,  
**Reel Capacity:** 58 ft.  
**Battery Compartment:** Conceals batteries inside arrow board panel

### SIGN DISPLAY

**Construction:** Extruded aluminum frame  
**Cross Members:** Extruded aluminum  
**Finish:** Aluminum  
**Salt Spray:** 1000 hours  
**UV Resistant:** 500 hours  
**Seal:** Weather resistant  
**Length:** 96"  
**Width:** 48"  
**Depth:** 3 3/8"  
**Visibility:** Up to 1 mile  
**Raising and Lowering of Display:** Winch  
**Flash Rate:** 30-40 flashes per minute  
**LED's:** (15 or 25) yellow/amber Par 46 LED's  
**Visor:** 360 degree plastic high impact

### POWER AND CHARGING

**Batteries:** (2) 18 amp batteries  
**Solar:** 40 watts of solar power  
**On-board Diagnostics to Monitor:** Solar, battery, and load  
**Regulator:** Built-in Controller with low voltage & high voltage disconnect.



# VEHICLE MOUNTED MODELS

We manufacture Vehicle Mounted Arrow Boards 15 and 25 lamp models in various sizes with numerous mounting options. The Silhouette offers is our lightest weight model and features an efficient 14 lamp design. All of our arrow boards feature an aluminum display with a folding frame activated using a 12V linear actuator with built-in limit switches and 6" stroke. They are finished with aluminum for a smooth look and corrosion resistance. The arrow board includes an auto raise/lower function when the unit is powered on or off. Units are powered using a cable that integrates into the vehicles existing power system. The built-in controller on the display face allows mode selection. Optional wireless and wired remotes are available. K&K's standard mounting choices include 90° Manual and 90° Auto, 180° Flip Manual, 180° Flip Auto, Low Profile, Over-the-cab, Rail, Hitch, Attenuator, and Skid.

In 2019, we introduced the industry's first wireless vehicle mounted arrow board - **TRUWIRELESS**. TruWireless eliminates all wires connecting the arrow board to the vehicle by utilizing solar to power the unit. Simply bolt the unit to the mount, select a mode, and it's operational. TruWireless is an option that can be applied to all arrow board models.

## FEATURES

- ▶ Arrow Board Meets MUTCD standards
- ▶ Photocell for Auto Dimming
- ▶ Super Bright LED Technology
- ▶ Easy to Operate & Maintain Arrow Board
- ▶ Powder Coat Finish
- ▶ 360° LED Visors
- ▶ Arrow Pattern Functions:
  - 8 for 14 lamp model
  - 8 for 15 lamp models
  - 13 for 25 lamp models
- ▶ 30-40 Flash Rate
- ▶ Mounting Options
- ▶ Durable Finish Resists the Elements
- ▶ Lightweight Construction
- ▶ Meets the 7 ft. min. mounting height with optional over-the-cab mounting hardware



# MODEL SELECTION

MODEL	DESCRIPTION	LAMPS
AV143055	30" x 55" Display. Black Finish. LED Lamps	14
AV153060	32" x 60" Display. Black Finish. LED Lamps	15
AV253060	32" x 60" Display. Black Finish. LED Lamps	25
AV153672	36" x 72" Display. Black Finish. LED Lamps	15
AV253672	36" x 72" Display. Black Finish. LED Lamps	25
AV154896	48" x 96" Display. Black Finish. LED Lamps	15
AV254896	48" x 96" Display. Black Finish. LED Lamps	25



Silhouette AV143055  
Low Profile Hitch Mount Shown



30" x 60" AV153060 / AV253060  
90° Auto Mount Shown



36" x 72" AV153672 / AV253672  
Over-the-Cab Low Profile Mount Shown



48" x 96" AV154896 / AV254896  
Low Profile Skid Mount Shown



48" x 96" AV154896 / AV254896  
Scorpion Mount Shown

## CONTROLLER

### Battery Status Indicator

**Light:** Indicates if solar is charging and its progress. Multi-color LED indicates the battery condition (low, fair, or good).

**Error LED:** Indicates low voltage disconnect or over voltage condition

**Mode Selector:** 14 lamp - 8 modes  
15 lamp - 8 modes  
25 lamp - 13 modes

## OPTIONAL REMOTES AVAILABLE

The K&K Vehicle Mounted Arrow Board has a standard built-in controller on the panel face. Optional wireless or wired remotes are available for easy operation and mode selection.

**TRUWIRELESS** Is our innovative option that uses solar energy to power the unit which eliminates integrating cables into the vehicle's power source.

## SIGN DISPLAY

**Construction Height:** standard 30" to 48"

**Length:** standard 60" to 96"

**Width:** 3 3/8"

**Material:** Extruded aluminum frame

**Salt Spray Fog:** 1,000 hours

**UV Resistance:** 500 hours

**LED bulbs:** 14, 15 or 25 yellow/amber Par 46 LED's with 360° high impact visor. Push on type connectors to prevent separation due to vibration during travel and operation.

## OPTIONS

- ▶ Three small amber indicator lights added to the back of display
- ▶ Upgrade to 25', 40', or 60' power cable
- ▶ Upgrade to TruWireless - complete wireless operation



**K&K Systems, inc.**  
**TRUWIRELESS**  
**MOUNT & GO VEHICLE ARROW BOARD**

Bolt the TruWireless to your vehicle's mount and you're set to go. The unit automatically powers on raising the display when you select an arrow mode on the wireless remote. Select the OFF mode to lower the panel. It's that easy. TruWireless uses solar energy stored in maintenance-free batteries concealed within the arrow board's display making TruWireless an all-in-one unit that can be easily mounted, removed, and remounted to a different vehicle quickly.

Solar panels provide power without the need of the vehicle's battery. K&K solar panels utilize the most up-to-date solar technology and electronics to maintain power levels through rain, sleet, heavy snow or strong winds. A built-in blocking diode prevents the reverse flow of electricity. The solar panel's heavy-duty aluminum frame makes it weather resistant.

TruWireless uses our wireless remote controller which allows mode selection and provides information such as battery status and condition, solar charging and progress, and errors. The Mode Selector activates arrow patterns for both the 15 lamp and 25 lamp configurations simply by turning the selector to the desired pattern.

## FEATURES

- ▶ Easy installation - Mount and Go design
- ▶ Low profile mount for less wind drag when not in use
- ▶ Remote Controller works up to 700 ft.
- ▶ On-board controller for operation without remote
- ▶ Low energy consuming LEDs with max light output
- ▶ Photocell for auto dimming
- ▶ Easy operation - 8 (15 lamps) or 13 (25 lamps) modes
- ▶ Durable powder coat finish
- ▶ 360° LED visors
- ▶ Meets MUTCD standards



# The Industry's First Completely Wireless Arrow Board for Vehicles

Actuator auto raises with power ON and lowers with power OFF

Cushioned supports

Photocell for auto-dimming

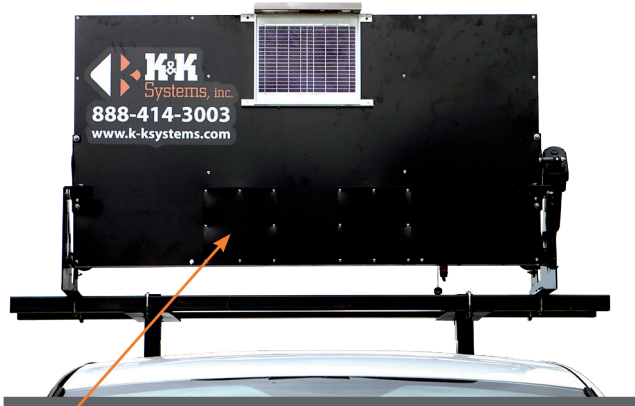
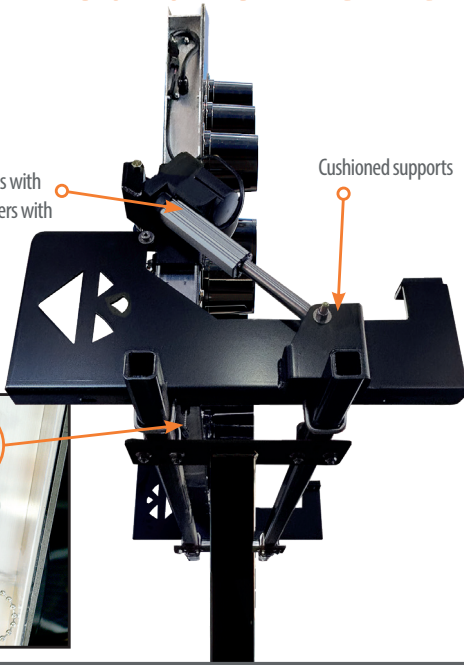
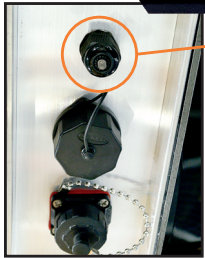

Battery access panels

Two 10 watt solar panels charge the unit in use and in transit



Low Profile Mount

## CONTROLLER

### Battery Status Indicator

**Light:** Indicates if solar is charging and its progress. Multi-color LED indicates the battery condition (low, fair, or good).

**Error LED:** Indicates low voltage disconnect or over voltage condition

**Mode Selector:** 15 lamp - 8 modes  
25 lamp - 13 modes



Wireless Remote  
optional

## SIGN DISPLAY

**Construction Height:** standard 30" to 48"

**Length:** standard 60" to 96"

**Width:** 3 3/8"

**Material:** Extruded aluminum frame

**Salt Spray Fog:** 1,000 hours

**UV Resistance:** 500 hours

**LED bulbs:** 15 or 25 yellow/amber Par 46 LED's with 360° high impact visor. Push on type connectors to prevent separation due to vibration during travel and operation.

## OPTIONS

- ▶ Three small amber indicator lights added to the back of display
- ▶ Wireless Remote
- ▶ Various Mounting Options
- ▶ Additional Autonomy



Shown with Rail Bars, Leg Extensions,  
and Low Profile Mount for  
over-the-cab placement



## **MOUNTS: LOW PROFILE, TAILGATE, HITCH, ATTENUATOR**

---

We manufacture a full range of Vehicle Arrow Board Mounts from high to low profile. From over-the-cab to hitch, K&K provides several solutions that allow you to use the Arrow Board in the manner specific to your needs. By combining the rail bars, leg extensions, and Low Profile mounts, your Arrow Board will fit neatly over-the-cab of your vehicle. When optional wireless remotes are paired with our automatic mounts operation means never having to leave the cab.



# MOUNTING BARS & HARDWARE

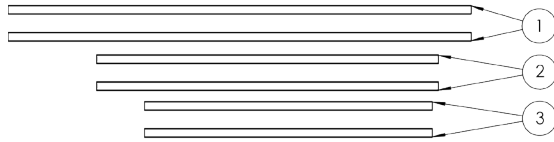

- 1. 2"x 2"x 11GAX 102" SQ TUBE
- 2. 2"x 2"x 11GAX 76" SQ TUBE
- 3. 2"x 2"x 11GAX 64" SQ TUBE
- 4. 1/2" 13 SQ BEND U-BOLT 2"x 3"
- 5. 1/2-13 NYLON INSERT LOCK NUT 18-8 SS
- 6. 1/2 x 1-1/4 FLAT WASHER 18-8 SS
- 7. 2" Square Plastic Cap Plug (Ribbed Plug)

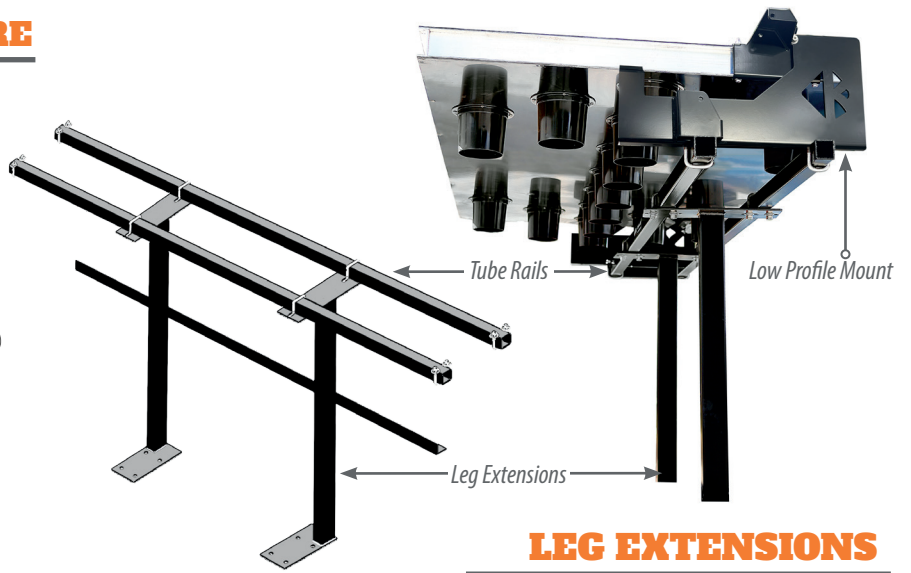
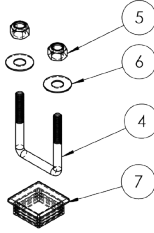

## LOW PROFILE

Low Profile Mount with auto raise/lower, 12V linear actuator with built-in limit switches and 6" stroke.

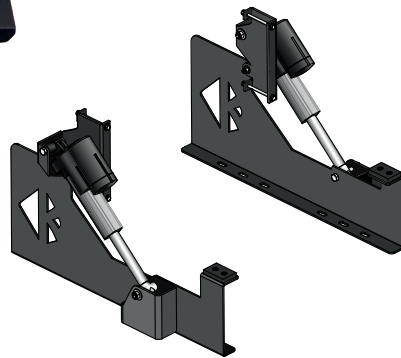
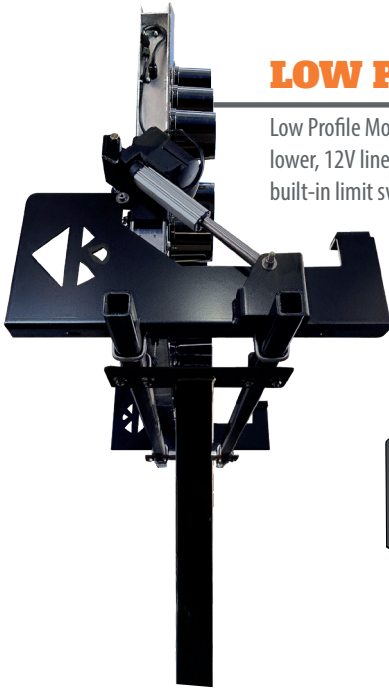

## LEG EXTENSIONS

Leg extensions for over the cab low profile mount. Includes U-bolts, center crossbar and top crossbars.

## TAILGATE

Two (2) brackets with adjusting cushions



## SCORPION AND VORTEQ MOUNTS

Manual; Actuator



## HITCH

Low Profile



High Profile

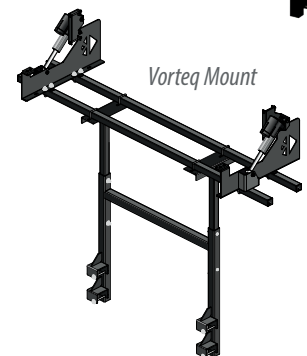
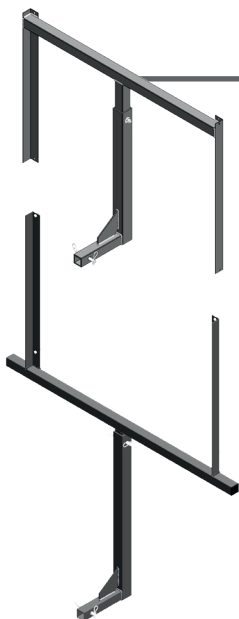

## **MOUNTS: 90° MANUAL**

---

We build Arrow Board Mounts to last. Our mounts are constructed using heavy gauge steel and square tubing that is powder coated.

The simplest and most economical of our Arrow Board mounts is our 90° Manual Mount. It is designed to fold down for less wind drag when not in use and convenient when clearance is a concern. Easily rotate the arrow board to the 90° position by simply pulling a pin.

The 90° Auto Mount is folded down using a 12V linear actuator that includes an auto raise/lower function when the unit is powered on/off.

*90° Manual*



## 90° MANUAL

Manual raise/lower



## 90° AUTO

Auto raise/lower, 12V linear actuator with built-in limit switches and 6" stroke

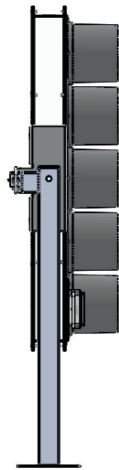
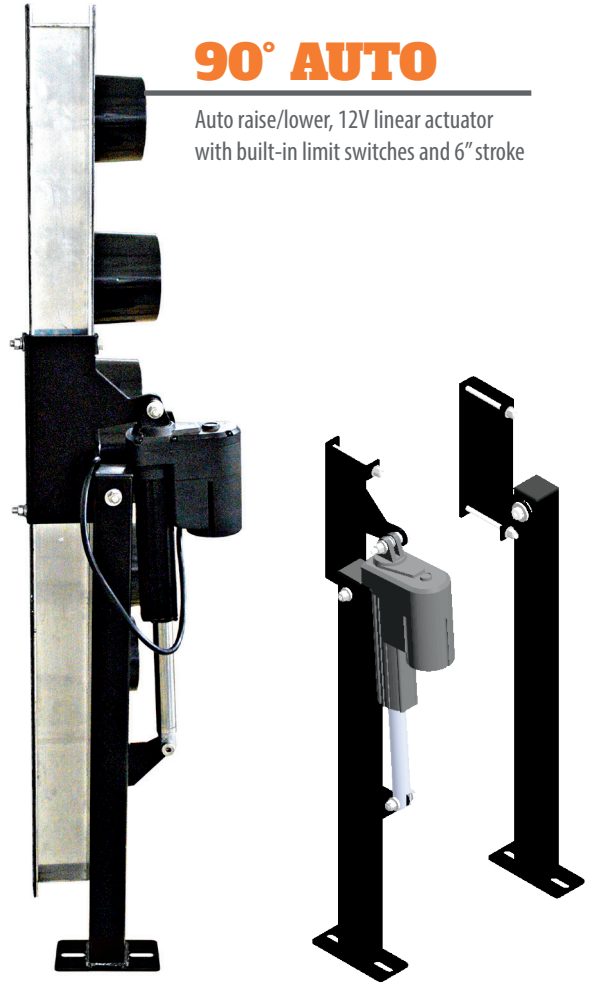

Upright Position

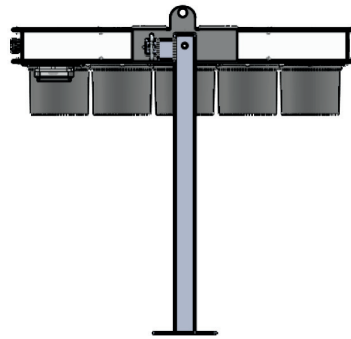

90° Position



# CONTROLLERS / FUNCTIONS

Every K&K Arrow Board has a standard built-in controller on the panel face. Optional wireless or wired remotes are available for easy operation and mode selection. It is used to select one of the display patterns or turn the unit on/off. The display patterns are listed below:

## 15 LIGHT PATTERNS:

- Warning Bar or Caution Bar
- Double Arrow
- Four Point Caution
- Right Arrow
- Left Arrow
- Sequencing Arrow Left
- Sequencing Arrow Right
- Sequencing Double Arrow

## 25 LIGHT PATTERNS:

(includes all 15 light patterns plus the following)

- Sequencing Chevron Left
- Sequencing Chevron Right
- Sequencing Arrow Head Moving Left
- Sequencing Arrow Head Moving Right
- Double Diamond
- All unused positions are considered OFF.



Optional Wireless Remote

Optional Wired Remote



Turn the Mode Selection knob to the desired pattern to activate.

The wired remote comes standard with a 20 ft. cable that connects to a weatherproof port on the bottom of the arrow board frame.

